

1. Recirculating ball bearing, drawn shell design, compact type, SLB series KH

The linear ball bearings **KH** are composed of a steel drawn shell, made of case hardened steel, a retainer made from engineered resin and precision balls. The drawn shell has pockets designed to allow the recirculation of the balls. This bearing type can only be used for linear movement and does not allow rotational movements.



1.1 Seals

The linear bearings of **KH** type are available in two different variants.

Without seals: **KH**

With contact seals: **KH..PP**

The seals have the dual function to prevent ingress of contaminants and the retention of lubricants in the bearings.

1.2 Lubrication

Linear bearings type **KH** are supplied coated with rust inhibiting oil. Linear bearings type **KH..PP** are supplied packaged with lithium soap grease.

1.3 Mounting tolerances

The table below shows the tolerances to be used for a proper bearing installation. They insure a precise and smooth motion.

1.4 Assembly

Linear bearings type **KH** are assembled with a light press fit. This insures not only the retention of the bearing but also the proper rounding of the unit. A proper fitting should be performed with the help of a mounting arbor as shown in **Fig. 1**.

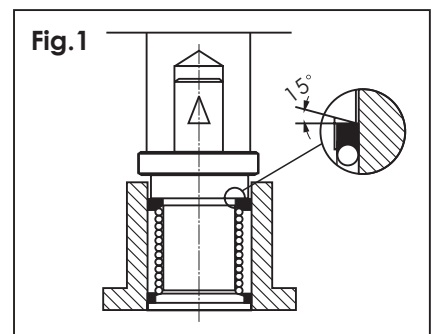

Table 1:
Recommended mounting tolerances

Housing material	General application		Vertical operation Precision application	
	Housing tolerance	Shaft tolerance	Housing tolerance	Shaft tolerance
Steel/cast iron	H7	h6	H6	i5
Aluminum/alloy	K7	h6	K6	i5

2. Linear recirculating ball bearing SLB precision series type LME - LMB

SLB linear recirculating bearing type **LME** and **LMB** are composed by a cylindrical outer ring, by a cage that retains the balls, by two end rings to retain the cage and/or, when required, contact seals.

All of the components are designed and assembled to optimize the unit performance.

The outer ring is suitably hardened to provide the longest possible life expectancy. The cage made of steel or engineered

resin, depending upon the type of bearing selected, provide the retention and allow the proper recirculation of the balls.

2.1 Characteristics of linear bearings type LME

2.1.1 High rigidity

Linear bearings with steel outer ring offer high rigidity due to the large number of balls in contact. The units can be supplied with a steel cage and, when low weight is required, with resin cage.

2.1.2 Ease of assembly

The standard units can carry load in every direction. The large variety of housing units and shaft supports allow simple and easy mounting.

2.1.3 Ease of replacement

These units follow internationally recognized boundary and are therefore dimensionally interchangeable with competitive units. Replacement due to wear or damage is quick and simple.

2.1.4 Complete range

The SLB range of products is quite broad.

The characteristics can be summarized as follows:

- A) Closed type - standard version
- B) Adjustable type - These units have a longitudinal slot that allows the reduction of the operating clearance and the optimization of the unit rigidity.
- C) Open type - These units have an opening that corresponds to a single recirculating channel (50 to 100 deg). These units are used in conjunction with long shafts that are typically supported along the entire length to reduce the elastic deflection. When mounted in a suitable housing, the units allow the adjustment of the operating clearance.
- D) Flanged type - These units have a flange on the outer ring to allow the mounting without conventional housings.

2.2 Seals

Linear bearings **LME** and **LMB** can be supplied in the following versions:

-Without seals - **LME/LMB**

-With contact seals - **LME..UU/LMB..UU**

The seals have the following functions:

- Prevent the ingress of contaminants
- Retain the lubricant in the bearing

In some applications, it may be necessary to use additional seals to prevent grease migration and thus prolong the maintenance interval.



3. Linear recirculating ball bearing SLB precision series type LME - LMB

3.1 Lubrication

Linear bearings type **LME-LMB** are supplied coated with rust inhibiting oil. Linear bearings type **LME..UU/LMB..UU** are supplied packaged with lithium soap grease.

3.2 Mounting tolerances

The bearing assembly should be performed as to insure operation with adequate clearance. Unsuitable operating clearance

could lead to poor running performance or lower than expected durability.

The operating clearance of the adjustable or open version of the linear bearings can be adjusted by elastically deforming the outer ring.

The suitable mounting tolerances for the mating components are shown in table 2.

Note: The operating clearance is application dependent and could be zero or negative (preload). In the latter case the friction as well as the smooth running should be checked for suitability.

3.1 Lubrication

Linear bearings type **LME-LMB** are supplied coated with rust inhibiting oil. Linear bearings type **LME..UU/LMB..UU** are supplied packaged with lithium soap grease.

3.2 Mounting tolerances

The bearing assembly should be performed as to insure operation with adequate clearance. Unsuitable operating clearance could lead to poor running performance or lower than expected durability.

The operating clearance of the adjustable or open version of the linear bearings can be adjusted by elastically deforming the outer ring.

The suitable mounting tolerances for the mating components are shown in table 2.

Note: The operating clearance is application dependent and could be zero or negative (preload). In the latter case the friction as well as the smooth running should be checked for suitability.

Table 2

Dimensional series	Shaft		Housing	
	Normal operating clearance	Operation without clearance	Normal operating clearance	Operation without clearance
LME	h6	j6	H7	J7

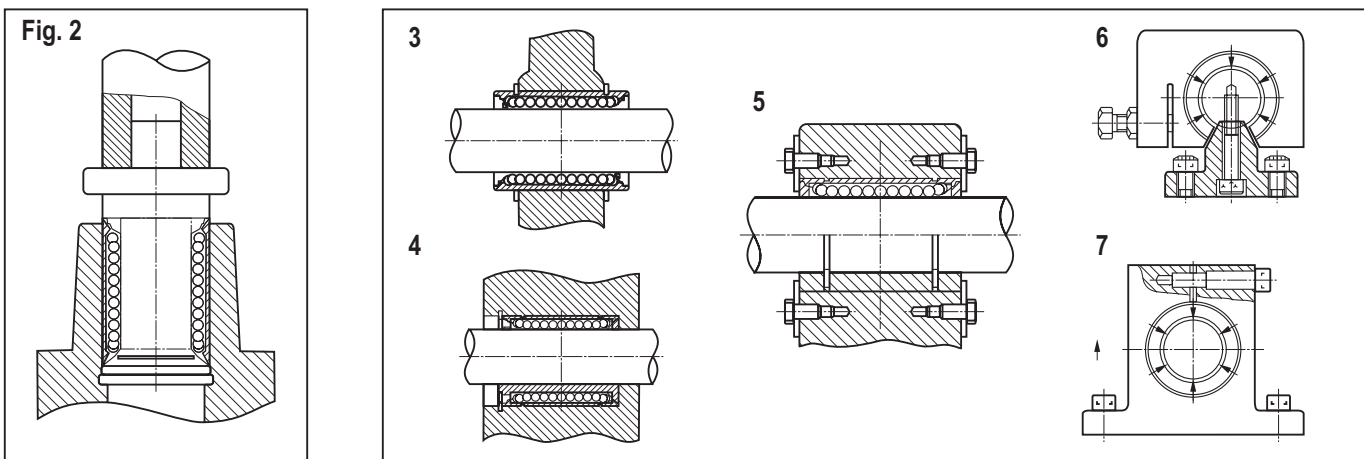

3.3 Installation

Some cleanliness precautions should be taken before assembling **SLB** linear bearings in their housings. Lack of cleanliness could lead to reduction of the bearing life. The installation of the units is not particularly difficult, though precaution should be observed to avoid potential damages to the unit. Direct pressing onto the cage retaining rings should be avoided. A suitable tool should be used (**Fig. 2**) to provide pressure on the rim of the outer ring. Once the bearing is mounted in the housing, the assembled unit should be installed onto the shaft paying attention not to score the shaft or to pop the balls from the bearing. When two shaft assemblies are assembled in a parallel assembly, the parallelism between the shafts should be checked to insure smooth running.

The mounting examples shown in **Fig. 3** through **7** should be used as guidelines to design and select the suitable bearings and support units.

4. Load ratings

Dynamic load rating C

The dynamic load rating C is a load of constant magnitude under which 90% of a statistically significant number of apparently identical bearings would reach a theoretical life of 50 km without the apparent appearance of metal fatigue.

Static load rating Co

The static load rating Co is defined as the load that would cause a permanent deformation equal to 1/10,000 of the ball diameter at the most stressed contact point.

4.1 Life of a linear ball bearing

Repeated stresses onto the contact surfaces could lead to material fatigue. This will lead to the appearance of surface pitting. The life of the unit is defined as the duration before the appearance of pitting.

4.1.1 Rated life(L)

The rated life L is the total traveled distance which 90% of a statistically significant number of apparently identical bearings would reach under the same operating conditions without the apparent appearance of metal fatigue.

$$L = \left(\frac{C}{P} \right)^3 \cdot 50 \quad (1)$$

L = rated life [km]

C = dynamic load ratings [N]

P = equivalent dynamic load [N]

When a system is subjected to a load equal to the dynamic load rating C the resulting life equal the rated life (50 km). The theoretical life of a linear bearing is affected by the load and by the operating conditions (temperature, vibration, shocks, load distribution, etc.). In such cases the theoretical life is calculated with the help of equation 2.

$$L = \left(\frac{f_H \cdot f_T \cdot f_C \cdot C}{f_w \cdot P} \right)^3 \cdot 50 \quad (2)$$

L = Rated life [km]

C = Dynamic load rating [N]

P = Equivalent dynamic load [N]

f_H = Hardness factor (see fig. 8)

f_T = Temperature factor (see fig. 9)

f_C = Contact coefficient (see table 4)

f_w = Load factor (see table 5)

The following equation (3) allows the conversion of the rated life in hours.

$$L_h = \left(\frac{L \cdot 10^3}{2 \cdot l_s \cdot n_1 \cdot 60} \right) \quad (3)$$

L_h = rated life [hours]

L_s = stroke length [m]

L = rated life [km]

n₁ = operating frequency [strokes/min]

. Hardness factor (fH)

The load ratings for the linear bearing are calculated with the raceway hardness equal or higher than 58 HRC. When the raceway hardness is reduced, the load rating of the bearing is also reduced and must be corrected using the accompanying chart (Fig.8).

Fig. 8 Raceway hardness factor

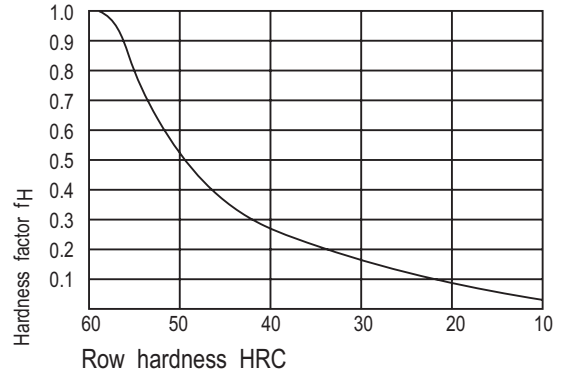

. Temperature factor (fT)

When a linear bearing operates at temperatures in excess of 100 deg. C, its hardness is affected and so is its ability to carry load. The load rating can be corrected by using the accompanying chart (Fig.9).

Fig. 9 Temperature factor

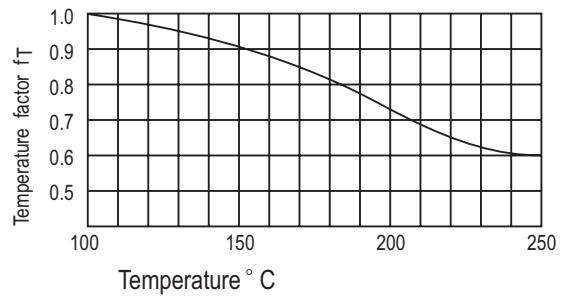

. Contact factor (fc)

Load biasing, attributed to mounting errors and multiple bearing assemblies can be accounted for by using the coefficient in table 3.

Table 3 - Contact factor

Number of bearings for shaft	Contact factor f _c
1	1.00
2	0.81
3	0.72
4	0.66
5	0.61

. Load factor (fw)

The loads acting on the linear units include payload, inertial effects during acceleration and deceleration as well as moment loads. All of these factors are difficult to assess and are further complicated by the potential presence of shocks and vibrations. A more practical solution involves the use of the coefficients in table 4.

Table 3 - Contact factor

Operating conditions	f _w
Low speed operations (<15 m/min) without shocks	1 - 1.5
Medium speed operation (60m/min) without shocks	1.5 - 2
High speed operations (>60m/min) with shocks	2 - 3.5

5. Static safety factor

For applications with a high requirement for accuracy and smooth running, the static safety factor f_s should be higher than the values shown in table 5 to prevent permanent deformation at the contact points.

$$f_s = \frac{C_o}{P_o}$$

f_s = static safety factor

P_o = static equivalent load (N)

C_o = static load rating (N)

Table 5 - Static safety factor

Operating conditions	f_s
Shafts subjected to small deflections and low shocks	1 ÷ 2
Elastic deflection can cross load the units	2 ÷ 4
System subjected to shock & vibration	3 ÷ 5

6. Friction

Linear recirculating ball bearings have a very low static coefficient of friction, virtually identical to the dynamic coefficient of friction. This results in low and uniform motion in any condition of load and speed without sick-slip.

$$F = \mu \cdot W + f \quad (4)$$

F = Friction force [N]

μ = Friction coefficient [-]

f = Seal drag [N]

w = Load [N]

The magnitude of the friction force is affected by several factors. The type of bearing, the operating conditions, the type and quantity of the lubricant, the presence or lack of seals all impact the overall frictional behavior. Standard seals can add between 2 and 5 N to the overall friction force.

The magnitude of the coefficient of friction depends upon the operating conditions such as load, moments and/or preload. Table 6 shows the dynamic coefficient of friction for each type of bearing under normal operating condition ($P/C \leq 0.2$) and proper assembly.

Table 6 - Friction coefficient

Type of bearing	Friction coefficient
KH	0.004 to 0.006
LME / LMB	0.002 to 0.003

7. OPERATING TEMPERATURE

The operating temperature ranges of the various bearings are shown in table 7. Should the operating temperature exceed the limits shown in the table, please contact fait International Engineering. Stainless steel units, without seals, can operate between -20/+120 deg. C

Table 7 - Operating temperature

Bearing type	Operating temperature
KH	-20 to +120 °C
LME / LMB	-20 to +110 °C