

Technical Information

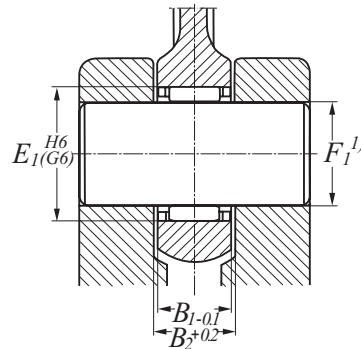

Inner bore F_w mm	Bearing number	Principal dimensions		Basic load ratings		Mounting dimensions		Web distance B_2	Mass g
		E_w mm	B_c mm	dynamic C r/min	static C_0	crank end B_1	piston end B_1 mm		
12	KZK 12x16x10	16.0	10	5100	5700	10		10.2	3.5
12	KZK 12x17x10	17.0	10	5900	5900	10		10.2	5.0
14	KZK 14x18x10	18.0	10	5600	6800	10		10.2	4.0
14	KZK 14.4x20.4x10	20.4	10	6800	6600	10		10.2	6.9
16	KZK 16x21x10	21.0	10	6500	7300	10		10.2	5.8
16	KZK 16x22x12	22.0	12	8800	9500	12	10	12.2	9.5
18	KZK 18x24x12	24.0	12	9200	10400	12		12.2	10.0
18	KZK 18x24x15	24.0	15	10500	12400	15	13	15.2	14.0
20	KZK 20x26x12	26.0	12	9700	117800	12		12.2	9.6
20	KZK 20x26x17	26.0	17	12200	15200	17	15	17.2	17.0
22	KZK 22x28x13	28.0	13	11100	14000	13	11	13.2	15.0
22	KZK 22x28x16	28.0	16	12400	16100	16	14	16.2	18.0
22	KZK 22x29x15	29.0	15	14200	17400	15	13	15.2	15.2
22	KZK 22x29x16	29.0	16	14200	17400	16	14	16.2	15.6
25	KZK 25x32x16	32.0	16	14500	17000	16	14	16.2	22.7
28	KZK 28x35x16	35.0	16	15100	20000	16	14	16.2	27.0
30	KZK 30x37x16	37.0	16	17200	24400	16	14	16.3	29.0
35	KZK 35x42x20	42.0	20	20800	32400	20	17	20.3	40.0
40	KZK 40x48x20	48.0	20	26000	40800	20	17	20.3	54.0

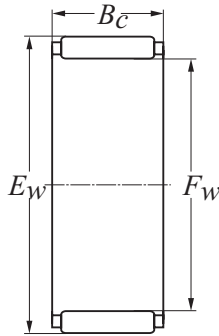